

INTEGRATED PRIVACY SET FITTING INSTRUCTIONS

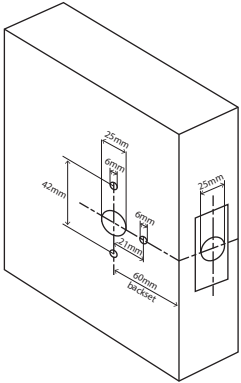

1. Measure the door thickness and mark the centre at the desired height for the latch.
2. Drill a 25mm (1") diameter hole through the door edge to a depth of at least 80mm. Ensure this hole is square to the door.
3. Mark the face of the door each side for drilling a 25mm diameter spindle hole. The centre of the spindle hole will need to be 60mm from the door edge (backset). Mark two 6mm screw holes at 21mm above and below the centre of the spindle hole. Mark one 6mm privacy pin hole at 21mm from the centre of the spindle hole towards the latch. For clean cut-outs, drill from both sides, meeting in the middle of the door.

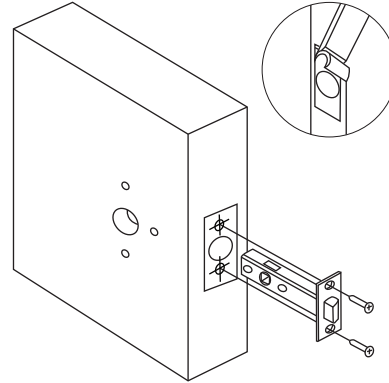

4. To change the handing of the latch, remove the outer faceplate, pull and rotate the latch tongue 180 degrees.
5. Insert the latch, scribe around the faceplate, remove, then chisel out recess to enable the latch faceplate to sit flush with the door edge.
6. Remove any loose saw dust and insert the latch, attach the faceplate and secure with the wood screws provided.

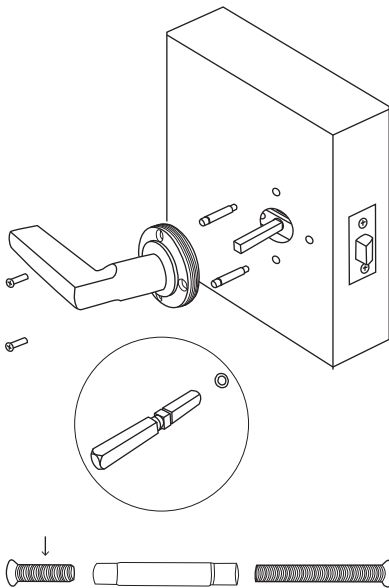

7. Remove the o-ring from the spindle. Insert the spindle into the latch so an even amount protrudes on each side of the door and slide the o-ring back onto the spindle & into groove.
8. Pull off the rose covers from the levers and unscrew the bolts from the threaded sleeves.
9. Insert the threaded sleeves into the oval holes in the back of the rose at two vertical positions. Screw the short bolts from the top of the rose through into the threaded sleeves.
10. Slide the handle over the spindle and press against the door.

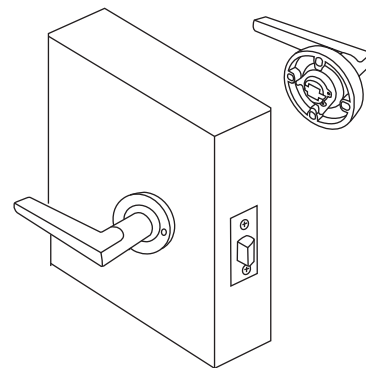

Note: The grubscrews may need a re-tighten after a bedding-in period. We recommend medium strength thread-lock to be used.

11. Insert the handle on the opposite side of the door over the spindle and tighten the long bolts through into the rose.
12. Press the rose covers onto the handles and ensure the integrated privacy pin holes are lined up. Tighten the grubscrews on the side of the levers onto the spindle for each side of the door. For the square rose (Futura Elite) press on the rose covers and tighten the grubscrews on the side of the roses.
13. Insert the integrated privacy pin through the rose and into the threaded slot on the latch.

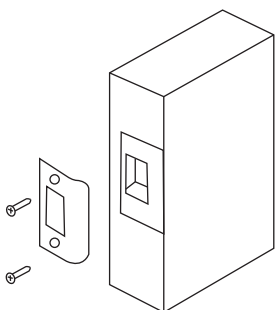

14. Close the door against the frame and mark the latch position for fitting of the striker.
15. Router or chisel so the striker fits flush, allowing for the plastic dustbox behind the striker.
16. Secure the striker with the wood screws provided. Test the door and if necessary, adjust the striker anti-rattle tab to take up any rattle.