

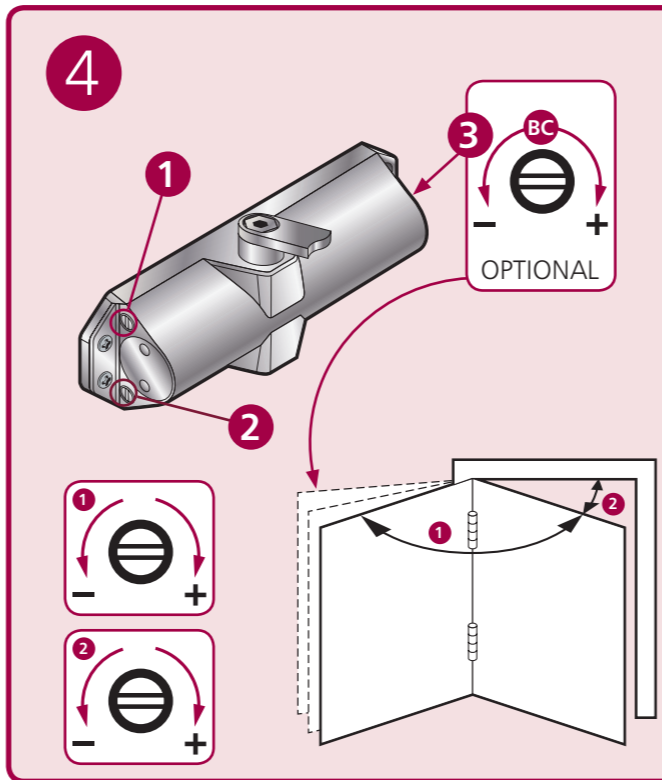

Standard Arm Closer TS3204

CE 34.1
1121
BS EN 1154
4 8 3 1 1 3

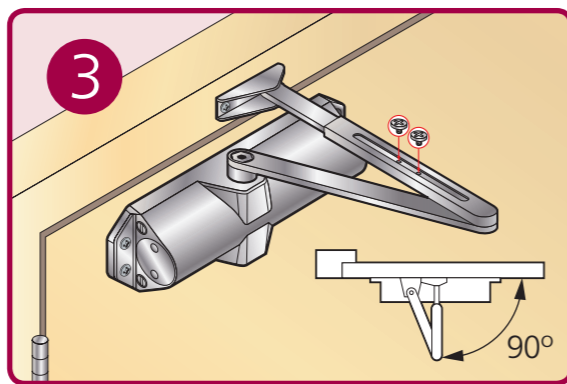
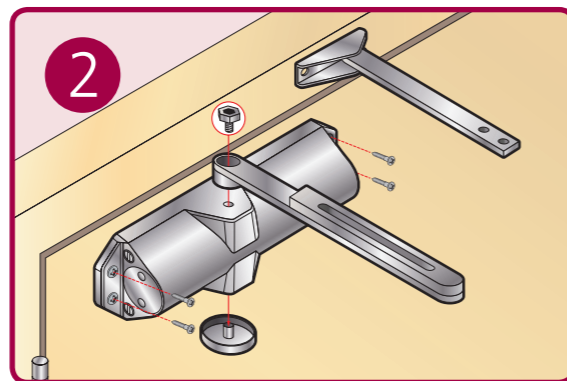
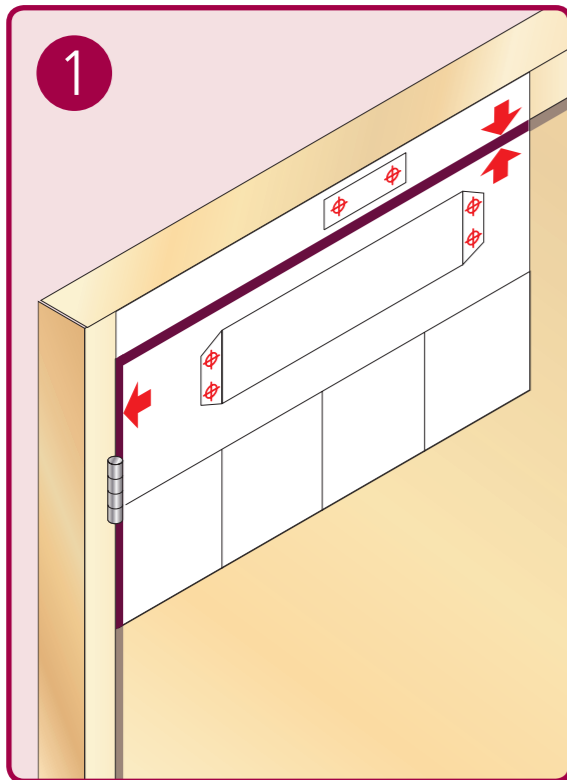
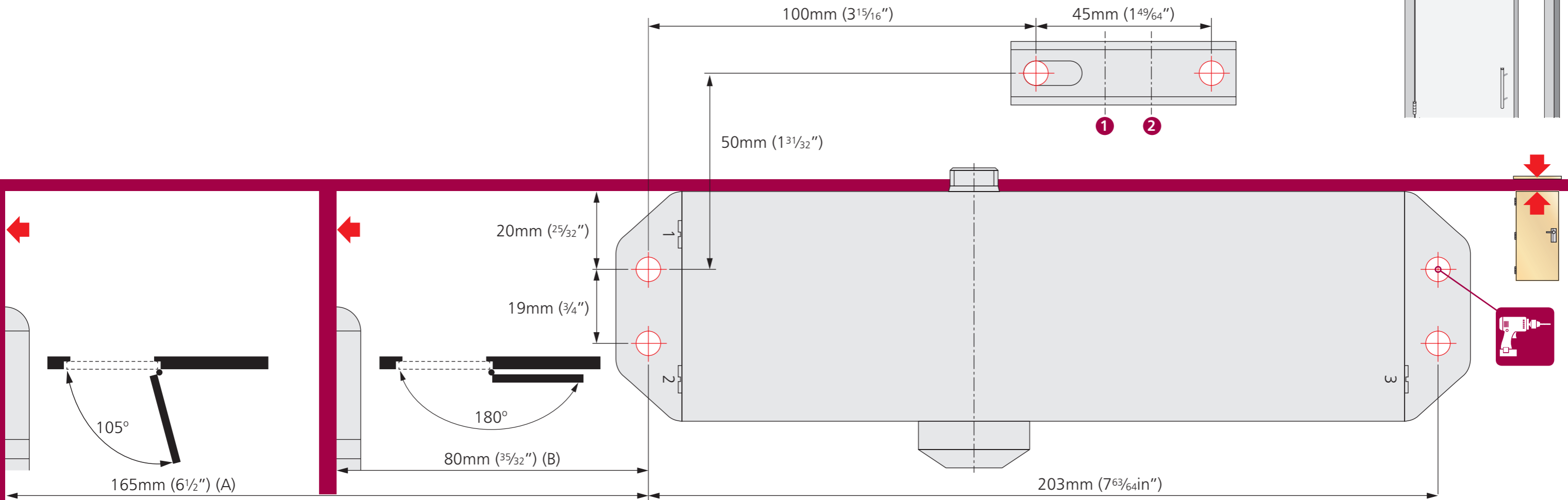
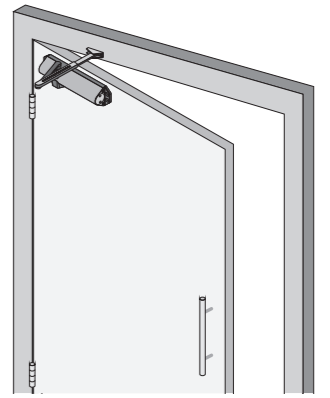

EN 2-4 Power Adjustment

Body Position	EN Size	Shoe Position	Max. door width	Max. opening angle
B	2	2	830mm	180°
B	3	1	930mm	180°
A	3	2	930mm	105°
A	4	1	1030mm	105°

THE PINION BOLT MUST BE TIGHTENED TO 12NM

NO PART OF THIS INSTRUCTION CAN BE COPIED OR STORED IN ANY WAY OR FORM MANUALLY OR ELECTRONICALLY WITHOUT THE FULL PERMISSION OF RUTLAND

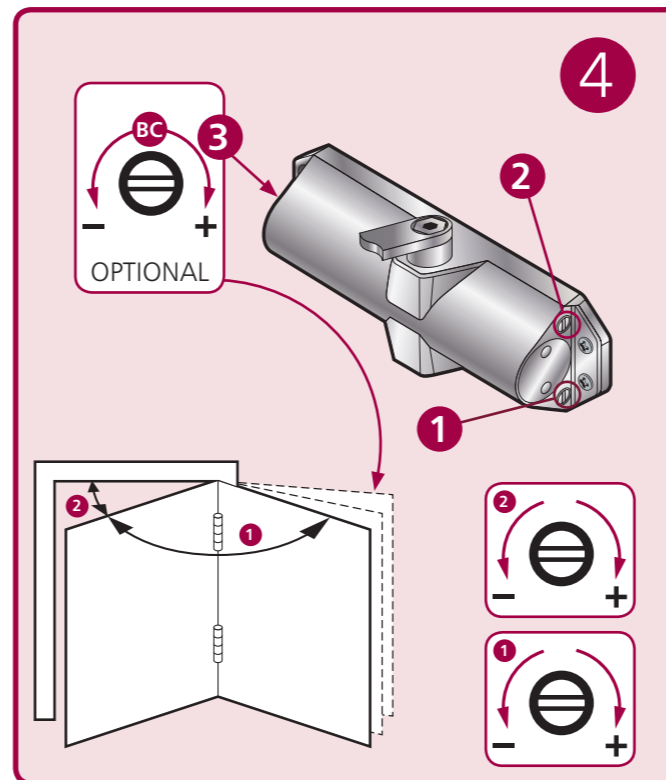
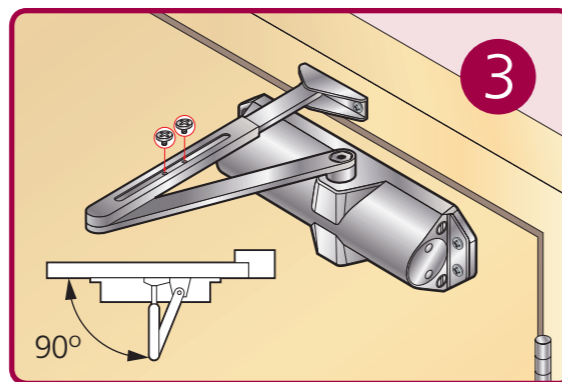
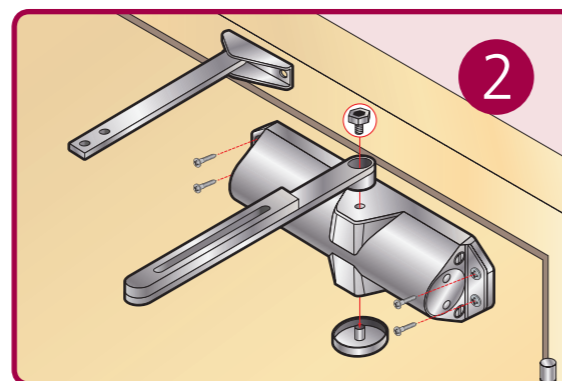
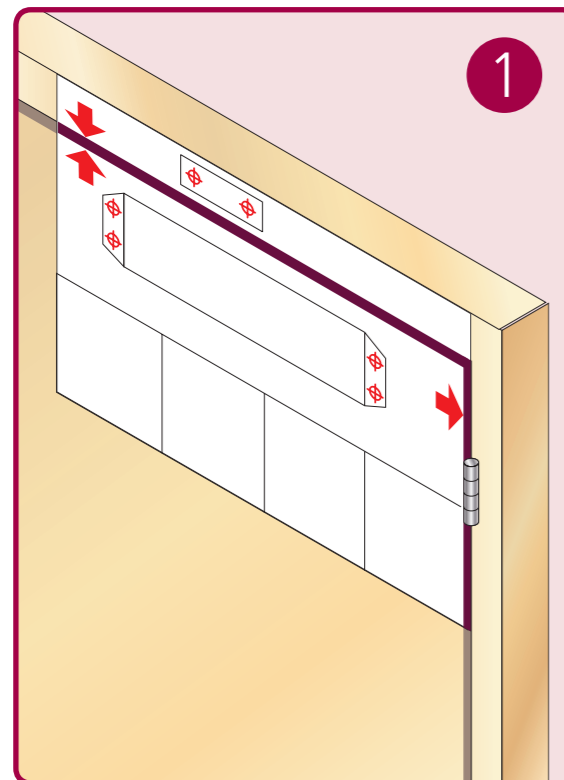
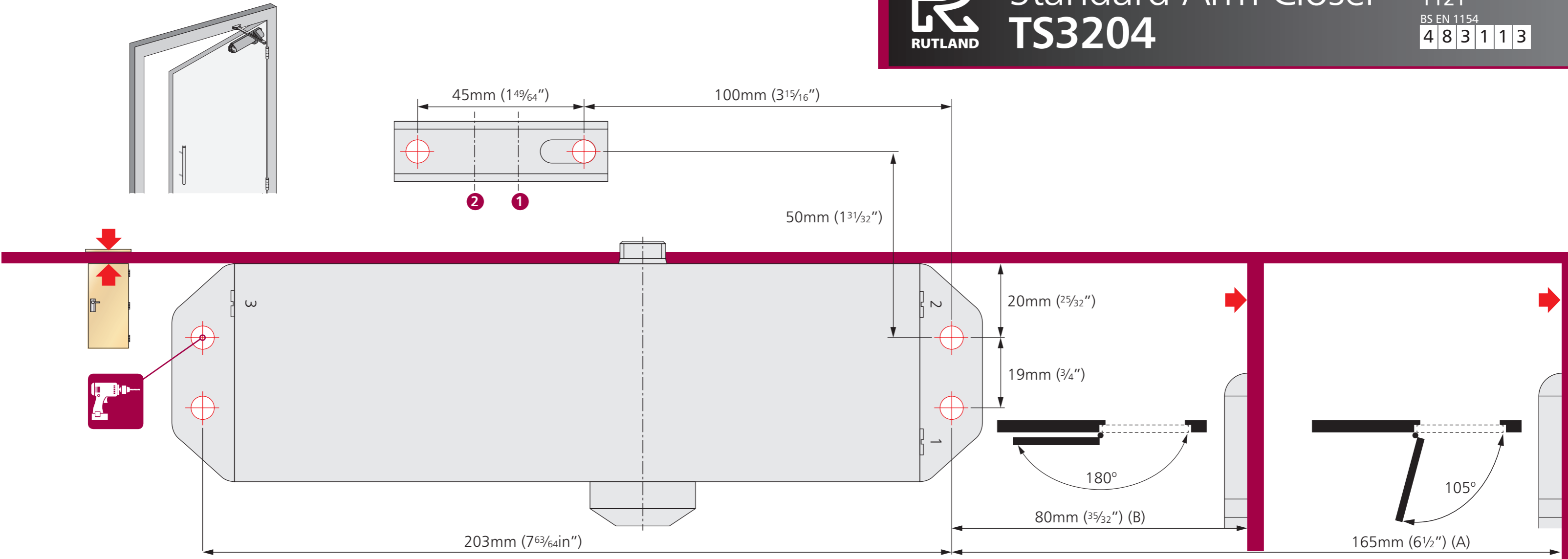

EN 2-4 Power Adjustment

Body Position	EN Size	Shoe Position	Max. door width	Max. opening angle
B	2	2	830mm	180°
B	3	1	930mm	180°
A	3	2	930mm	105°
A	4	1	1030mm	105°

THE PINION BOLT MUST BE TIGHTENED TO 12NM

NO PART OF THIS INSTRUCTION CAN BE COPIED OR STORED IN ANY WAY OR FORM MANUALLY OR ELECTRONICALLY WITHOUT THE FULL PERMISSION OF RUTLAND